

AIR-SUSPENSION

Dunlop Systems and Components
Het Wegdam 22
7496 CA Hengevelde
The Netherlands
Tel.: +31-547-333065
Fax: +31-547-333068
Website: www.dunlopsystems.com

Auxiliary Air Suspension

Art. nr.: L.CONN.C.M

Designed for:
Ford Connect, Tourneo



From: 2003 - Present

1. Introduction

This air suspension kit has been especially developed for the Ford Connect. To ensure the correct installation of the air suspension, we strongly recommend to read these instructions thoroughly before commencing any installation work. All components are supplied with bolts, washers and nuts. The installation should only be carried out by a suitably qualified mechanic/ installation company. We will not accept responsibility for faults or defects arising from incorrect installation and such action will render the guarantee void.

**Do not forget to send a copy of the complete filled out manufacturers declaration by post, fax or e-mail to Dunlop Systems and Components, after installing this kit.
Signed by a qualified installer.**

Artikel number:

L.CONN.C.M - Auxiliary air suspension

Index

1. Introduction	2.
2. Content of the kit	3.
3. Installation of brackets and air bellows	4.
4. Connecting air hose to;	
•Valves (standard)	
•Valves and gauges (optional)	5.
5. Operation	6.
6. Maintenance	6.
7. Completion	6.
8. Photos	7.

2. Content of the air suspension kit

<i>Nr.</i>	<i>Description</i>	<i>Quantity</i>
1.	Upper bracket – right hand	1
2.	Upper bracket – left hand	1
3.	Strap	2
4.	Lower bracket – left hand	1
5.	Lower bracket – right hand	2
6.	Air spring 170-2	2

Not in the assembly drawing

- All bolt and nuts needed
- Bleu and black air lines
- Tie wraps
- Schrader valves
- Declaration of conformity
- Installation manual

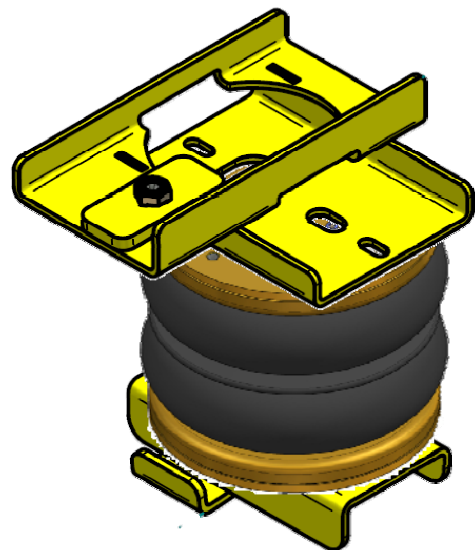
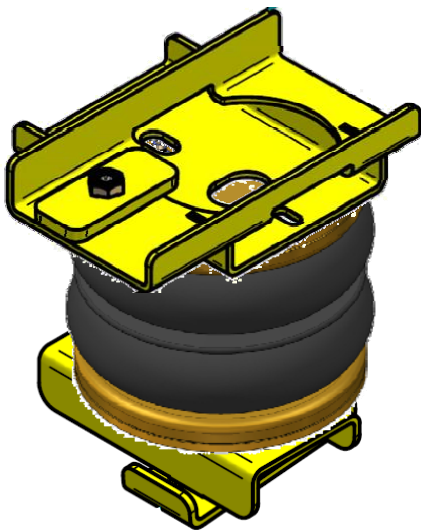

3. Installation of brackets and air bellows.

Ensure you have enough space between chassis and the rear axle to provide the installation. If needed use a jack. Install one side first, to avoid mistakes.

Think of your safety first !! Always use axle struts!!!

Assembling the air spring assemblies .

Connect the air tube to the air spring. Black is left and blue is right. Then mount the bottom bracket to the air spring . Don't tighten the bolts. (see pictures 02 – 06)

Preparing the vehicle .

Remove the U-bolts and the bump stops rebound. If necessary lift the back of the vehicle to provide more room for installing the air spring assemblies. Also remove the bump stop. (see pictures 07 – 09)

Attaching the upper bracket to the chassis.

Insert the connection plate into the hole in the chassis. Fixate the upper bracket. (see pictures 10 – 13)

Attaching the the air spring assemblies on the axle.

The bottom bracket will come down upon the leave springs. Lower back of the vehicle and secure the bottom brackets with the U-bolts. (see picture 14 – 16)

Securing the air springs.

Bring the vehicle to it's ride level. Align the air spring and than tighten all bolts . (see picture 17 – 18)

4. Connecting air hose to;

- **Valves (standard)**

Attach the valves to properly protected and solid but accessible place.
Some examples:



- At the rear on the bumper
- At the rear beside the license plate
- On the side just before a rear wheel on the chassis
- Beside the fuel cap
- Or any other place you prefer

- **Valves and gauges (optional)**

Attach the panel to properly protected and solid but accessible place.
Some examples:

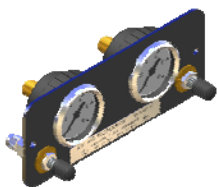

- In the cabin within reach and sight of the driver
- Or any other dry place you prefer

Bring the air tubes to the valves (check; left is black, right is blue) and connect them. Ensure tightened by hand and then 1 total turn is o.k..

Note;

- *guide the air tubes along the brake lines to the chassis, this is the safest way to avoid tearing.*
- *Avoid to tight ty-raps, air hose must remain easily to shift at a ty-rap connection point.*
- *To shorten air tube; cut it straight*

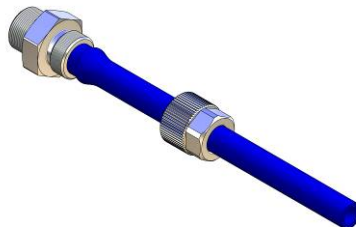
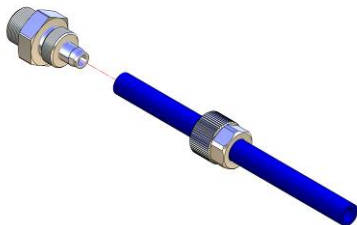

Keep the air tubes away from:

- heat of the exhaust
- debris of dirt & splatter
- obstacles like branches, etc.
- sharp-edges

5. Operation

With a normal tire pump you can check the pressure in the tires. The rear of the vehicle should be a little higher than the front.

Important - minimal pressure **0.5 bar.**
 - maximal pressure **7.0 bar.**

6. Maintenance

After installing, Spray body wax on the steel parts. The air suspension kit does not need much service. Check ones in a while the pressure of the air bellows. If you wash your car also clean your air bellows by spraying off the dirt & debris.

7. Completion

Dunlop Systems and Components wishes you a lot of pleasure with our air suspension kit. Ensure proper functioning of our air suspension, we advise to (let) check/ control the system by qualified personnel frequently. It is important to spray all the steel parts with body wax.

Do not forget to send a copy of the complete filled out manufacturers declaration by post, fax or e-mail to Dunlop Systems and Components, after installing this kit. Signed by a qualified installer.

Modifications to the system are only allowed to be done by Dunlop systems and Components. For questions you can always call Dunlop Systems and Components.
Tel. 0031 (0) 547-333065.

8. Photos

1



2



3

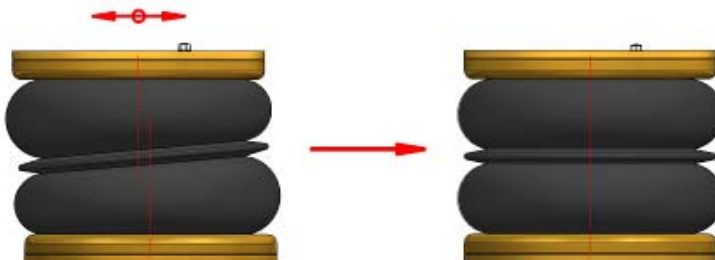

Spring out of alignment—mounting plate axes offset

Spring in alignment—mounting plates parallel and coaxial



CAUTION!

Before fully tightening the bolts that secure the air spring to the upper and lower brackets, set the vehicle at ride height (spring height approximately 13.5cm) and ensure that the springs are correctly aligned.

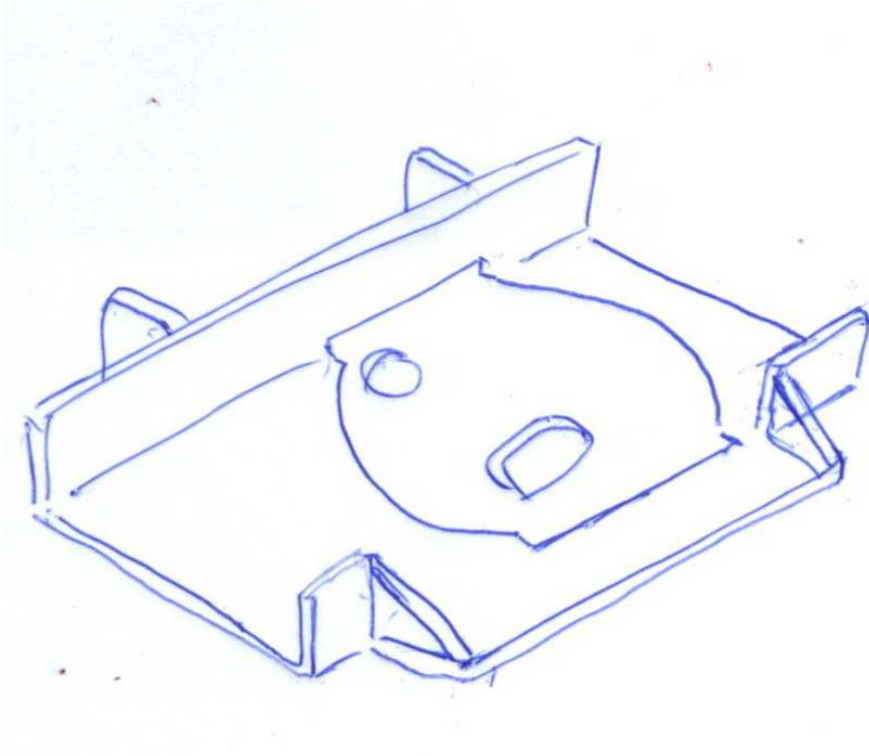

Top plate modification for Ford Connect (with cross member)